



Dell Networking 330 Series Access Points Installation Guide

The Dell 330 Series Wireless Access Points (W-AP334, W-IAP334, W-AP335, and W-IAP335) support IEEE 802.11ac standards for high-performance WLAN. This device is equipped with two dual-band radios, which provide network access and monitor the network simultaneously. This access point delivers high-performance 802.11n 2.4 GHz and 802.11ac 5 GHz functionality, while also supporting 802.11a/b/g wireless services. Multi-user Multiple-in, Multiple-output (MU-MIMO) is enabled when operating in 5GHz mode for optimal performance.

The W-AP334 and W-AP335 access points work in conjunction with an Dell controller, while the W-IAP334 and W-IAP335 access points can be configured using a built-in virtual controller.

The 330 Series wireless access points provides the following capabilities:

- IEEE 802.11a/b/g/n/ac wireless access point
- IEEE 802.11a/b/g/n/ac wireless air monitor
- IEEE 802.11a/b/g/n/ac spectrum monitor
- Compatible with IEEE 802.3at power sources
- Centralized management, configuration and upgrades
- Integrated Bluetooth Low Energy (BLE) radio

Package Contents

- 330 Series access point
- 9/16" and 15/16" Ceiling Rail Adapters
- *Dell Networking 330 Series Access Points Installation Guide* (this document)
- *Dell Networking 330 Series Access Points Regulatory Compliance and Safety Information Guide*
- *Dell Networking W-Series Instant Quick Start Guide* (W-IAP334 and W-IAP335 only)
- *Dell Networking W-Series Instant Access Point Professional Installation Supplement* (W-IAP334 only)



Note: Inform your supplier if there are any incorrect, missing, or damaged parts. If possible, retain the carton, including the original packing materials. Use these materials to repack and return the unit to the supplier if needed.

Software

The W-AP334 and W-AP335 access points require Dell Networking W-Series ArubaOS 6.5.0 or higher. For additional information, refer to the *W-Series ArubaOS User Guide* and *W-Series ArubaOS Quick Start Guide*.

The W-IAP324 and W-IAP325 remote access points require Dell Networking W-Series Instant 4.3.0 or higher. For additional information, refer to the *W-Series Instant User Guide* and *W-Series Instant Quick Start Guide*.



CAUTION: Dell access points are classified as radio transmission devices, and are subject to government regulations of the host country. The network administrator(s) is/are responsible for ensuring that configuration and operation of this equipment meet all regulatory standards of their country/domain. For complete list of approved channels in your country, refer to the *Dell Networking W-Series Downloadable Regulatory Table Release Notes* at download.dell-pcw.com.



ATTENTION: Les points d'accès sont considérés comme appareils de transmission radio et sont soumis aux réglementations gouvernementales du pays dans lequel ils sont déployés. Le ou les administrateurs réseau doivent s'assurer que la configuration et le fonctionnement de cet équipement sont conformes aux normes de leurs pays. De façon plus précise, les points d'accès doivent employer des canaux adaptés à leur emplacement physique. Pour obtenir une liste complète des canaux approuvés dans votre pays, reportez-vous aux notes de version *Dell Networking W-Series Downloadable Regulatory Table Release Note (DRT)* à l'adresse download.dell-pcw.com.

330 Series Hardware Overview

Figure 1 LEDs

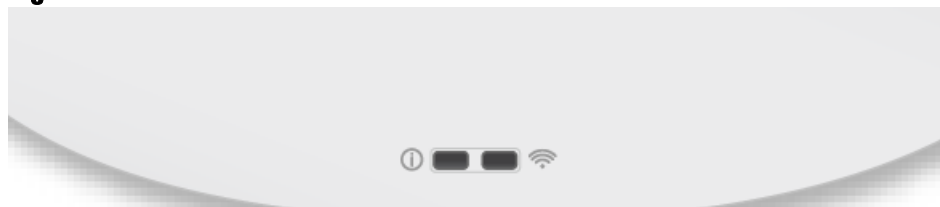

LEDs

The 330 Series access points have two LEDs that indicate the system and radio status.

The LEDs have three operating modes that can be selected in the system management software:

- Default mode: refer to Table 1
- Off mode: LEDs are off
- Blink mode: LEDs blink green

Table 1: 330 Series LED Status Indicators

LED	Color/State	Meaning
System Status (Left)	Off	Device powered off
	Green- Blinking*	Device booting, not ready for use
	Green- Solid	Device ready for use
	Green- Flashing**	Device operating in restricted mode. Meets one of the following conditions: <ul style="list-style-type: none"> • Uplink negotiated in sub-optimal speed (<1Gbps), or • Ethernet radio is in non High-Throughput (HT) mode
Radio Status (Right)	Off	Device powered off; or both radios disabled
	Green- Solid	Both radios enabled in access mode
	Green- Blinking	One radio enabled in access mode
	Amber- Solid	Both radios enabled in monitor mode
	Amber- Blinking	One radio enabled in access mode; one radio disabled
	Alternating	<ul style="list-style-type: none"> • Green: one radio in access mode • Amber: one radio in monitor mode • Red: one radio in error mode

*Blinking: 1s on/1s off
**Flashing: off a fraction of a second every 2s

External Antenna Connectors

The W-AP334 and W-IAP334 access points are equipped with four external antenna connectors located on the front corners of the access point (see).

Figure 2 External Antenna Connectors



CAUTION: The Equivalent Isotropically Radiated Power (EIRP) levels for all external antenna devices must not exceed the regulatory limit set by the host country/domain. Installers are required to record the antenna gain for this device in the system management software.



ATTENTION: Les appareils munis d'antennes externes doivent utiliser uniquement des antennes certifiées par le fabricant. Le ou les administrateurs doivent s'assurer que les niveaux de puissance isotrope rayonnée équivalente (PIRE) de tous les appareils munis d'antennes externes sont conformes aux normes réglementaires du pays/domaine hôte. Le ou les installateurs doivent enregistrer le gain d'antenne (dBi) de cet appareil dans le logiciel de gestion du système.

USB Interface

The 330 Series is equipped with a USB port for connectivity with cellular modems and other USB client devices.

When powered by an 802.3at or DC power source, the USB port can supply power up to 5W/1A.

When powered by an 802.3af source, the USB port is disabled.

Figure 3 USB Port



Console Port

The console port allows the user to connect the access point directly to a serial terminal or laptop for local management. Connect the device to a terminal or terminal server using an Ethernet cable.

Figure 4 Back Panel

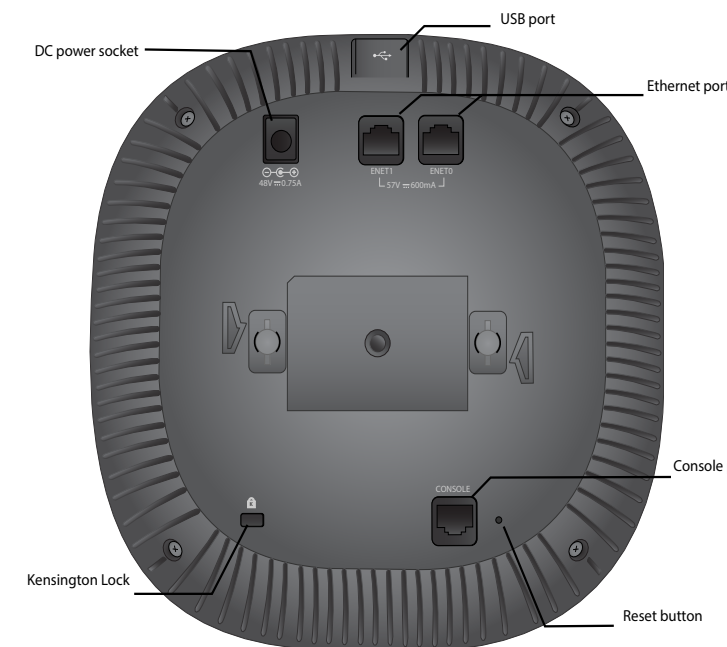

The port is an RJ45 connector with pin-out details in .

Ethernet Ports

The back panel of the 330 Series access point is equipped with two Ethernet ports (ENET0 and ENET1) to support wired-network connectivity. These ports support IEEE 802.3at Power over Ethernet (PoE) compliant sources, accepting 56V DC (nominal) as a standard powered device (PD) from power sourcing equipment, such as a PoE midspan injector or network infrastructure that supports PoE.

Figure 5 RJ45 Gigabit Port Pin-Out

1000Base-T Gigabit Ethernet Port	RJ-45 Female Pin-Out	Signal Name	Function
1	1	BI_DA+	Bi-directional pair +A
2	2	BI_DA-	Bi-directional pair -A
3	3	BI_DB+	Bi-directional pair +B
4	4	BI_DC+	Bi-directional pair +C
5	5	BI_DC-	Bi-directional pair -C
6	6	BI_DB-	Bi-directional pair -B
7	7	BI_DD+	Bi-directional pair +D
8	8	BI_DD-	Bi-directional pair -D

- The ENET0: 100/1000/2500Base-T auto-sensing MDI/MDX RJ45 port.
- The ENET1: 100/1000Base-T auto-sensing MDI/MDX RJ45 port.

Kensington Lock Slot

The 330 Series is equipped with a Kensington lock slot for additional security, shown in Figure 3.

Reset Button

The reset button can be used to return the access point to factory default settings. To reset the access point, refer to the steps below:

1. Power off the access point.
2. Press and hold the reset button using a small, narrow object, such as a paperclip.
3. Power-on the access point without releasing the reset button. The power LED will flash within 5 seconds.
4. Release the reset button.

The power LED will flash again within 15 seconds indicating that the reset is completed. The access point will now continue to boot with the factory default settings.

Power

The ENET0 and ENET1 ports support PoE-in, allowing one port to draw power from an 802.3at source.

If PoE is not available, the access point has a single 48V/28W DC power input to support the AP-AC-48V36 AC-to-DC power adapter kit (sold separately).

When both 802.3at and DC power sources are available, the DC power source will take precedence. The access point will simultaneously draw a minimal current from the PoE source. In the event that the DC source fails, the access point will switch to the 802.3at source.

The 330 Series operates without restrictions when powered by a DC or 802.3at PoE source. In this mode the USB interface is enabled and supports up to 1A/5W to a powered device (PD).

Table 2 Power Modes

Power Source	Restrictions	USB
DC (AP-AC-48V36W)	No restrictions	1A/5W
PoE 802.3at	No restrictions	1A/5W

Before You Begin



CAUTION: FCC Statement: Improper termination of access points installed in the United States configured to non-US model controllers is a violation of the FCC grant of equipment authorization. Any such willful or intentional violation may result in a requirement by the FCC for immediate termination of operation and may be subject to forfeiture (47 CFR 1.80).



ATTENTION: Déclaration FCC l'arrêt incorrect des points d'accès installés aux États-Unis qui sont configurés sur des contrôleurs autres que le modèle agréé aux États-Unis est considéré comme contrevenant à l'homologation FCC. Toute violation délibérée ou intentionnelle de cette condition peut entraîner une injonction d'arrêt immédiat de son utilisation par la FCC et peut déboucher sur la confiscation de l'équipement (47 CFR 1.80).



CAUTION: EU Statement: Lower power radio LAN product operating in 2.4 GHz and 5 GHz bands. Please refer to the *W-Series ArubaOS User Guide/W-Series Instant User Guide* for details on restrictions.

Produit réseau local radio basse puissance operant dans la bande fréquence 2.4 GHz et 5 GHz. Merci de vous référer au *W-Series ArubaOS User Guide/W-Series Instant User Guide* pour les détails des restrictions.

Low Power FunkLAN Produkt, das im 2.4 GHz und im 5 GHz Band arbeitet. Weitere Informationen bezüglich Einschränkungen finden Sie im *W-Series ArubaOS User Guide/W-Series Instant User Guide*.

Apparati Radio LAN a bassa Potenza, operanti a 2.4 GHz e 5 GHz. Fare riferimento alla *W-Series ArubaOS User Guide/W-Series Instant User Guide* per avere informazioni dettagliate sulle restrizioni.

Access Point Pre-Installation Checklist

Before installing your 330 Series access point, ensure that you have the following:

- CAT5E cable or better
- One of the following power sources:
 - IEEE 802.3at or 802.3af-compliant Power over Ethernet (PoE) source. The PoE source can be any power source equipment (PSE) controller or midspan PSE device
 - Dell AP-AC-48V36 adapter kit (sold separately)

For W-AP334 and W-AP335 only:

- Dell controller provisioned on the network:
 - Layer 2/3 network connectivity to your access point
- One of the following network services:
 - Aruba Discovery Protocol (ADP)
 - DNS server with an "A" record
 - DHCP Server with vendor-specific options



Note: Dell, in compliance with governmental requirements, has designed the 330 Series access points so that only authorized network administrators can change the settings. For more information about access point configuration, refer to the *W-Series ArubaOS Quick Start Guide/W-Series Instant Quick Start Guide* and *W-Series ArubaOS User Guide/W-Series Instant User Guide*.

Verifying Pre-Installation Connectivity



Note: The instructions for the following section are applicable to W-AP334 and W-AP335 access points only.

Before installing access points in a network environment, make sure that they are able to locate and connect to the controller after power on.

Specifically, you must verify the following conditions:

- When connected to the network, each access point is assigned a valid IP address
- Access points are able to locate the controller

Refer to the *W-Series ArubaOS Quick Start Guide* for instructions on locating and connecting to the controller.

Pre-Installation Network Requirements

After WLAN planning is complete and the appropriate products and their placement have been determined, the Dell controller(s) must be installed and initial setup performed before the Dell access points are deployed.

For initial setup of the controller, refer to the *W-Series ArubaOS Quick Start Guide* for the software version installed on your controller.

Identifying Specific Installation Locations

You can mount the 330 Series access point on a wall or on the ceiling. Use the access point placement map generated by Dell's RF Plan software application to determine the proper installation location(s). Each location should be as close as possible to the center of the intended coverage area and should be free from obstructions or obvious sources of interference. These RF absorbers/reflectors/interference sources will impact RF propagation and should have been accounted for during the planning phase and adjusted for in RF plan.

Identifying Known RF Absorbers/Reflectors/Interference Sources

Identifying known RF absorbers, reflectors, and interference sources while in the field during the installation phase is critical. Make sure that these sources are taken into consideration when you attach an access point to its fixed location. Examples of sources that degrade RF performance include:

- Cement and brick
- Objects that contain water
- Metal
- Microwave ovens
- Wireless phones and headsets

Installing the Access Point

Refer to the following steps to install your Dell 330 Series access point using the AP Ceiling Rail Mount Kit (AP-220-MNT-C1).



CAUTION: All Dell access points should be professionally installed by certified technician. The technician is responsible for ensuring that grounding is available that meets applicable regional regulatory and electrical standards.



ATTENTION: Tous les points d'accès Dell doivent impérativement être installés par un professionnel agréé. Ce dernier doit s'assurer que l'appareil est mis à la terre et que le circuit de mise à la terre est conforme aux codes électriques nationaux en vigueur.

Using the Ceiling Rail Adapter

The 330 Series ships with two ceiling rail adapters for 9/16" and 15/16" ceiling rails. Additional wall mount adapters and ceiling rail adapters for other rail styles are available as accessory kits.



CAUTION: The installer is responsible for securing the access point onto the ceiling tile rail in accordance with the steps below. Failure to properly install this product may result in physical injury and/or damage to property.



ATTENTION: L'installateur est chargé de sécuriser le point d'accès sur le rail de montage au plafond en suivant la procédure ci-après. Toute installation incorrecte du produit peut entraîner des blessures physiques et/ou des dommages matériels.

1. Pull the necessary cables through a prepared hole in the ceiling tile near where the access point will be placed.
2. Place the adapter against the back of the access point with the adapter at an angle of approximately 30 degrees to the tabs (see [Figure 6](#)).
3. Twist the adapter clockwise until it snaps into place in the tabs (see [Figure 6](#)).

Figure 6 Attaching the Ceiling Rail Adapter

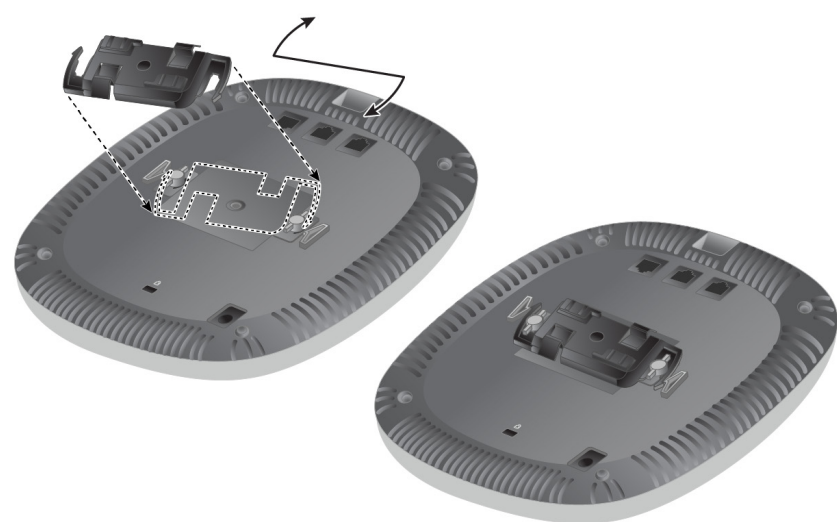

4. If necessary, connect the console cable to the console port on the back of the access point.
5. Hold the access point next to the ceiling tile rail with the ceiling tile rail mounting slots at approximately a 30-degree angle to the ceiling tile rail (see [Figure 7](#)). Make sure that any cable slack is above the ceiling tile.
6. Pushing toward the ceiling tile, rotate the access point clockwise until the device clicks into place on the ceiling tile rail.

Figure 7 Mounting the Access Point

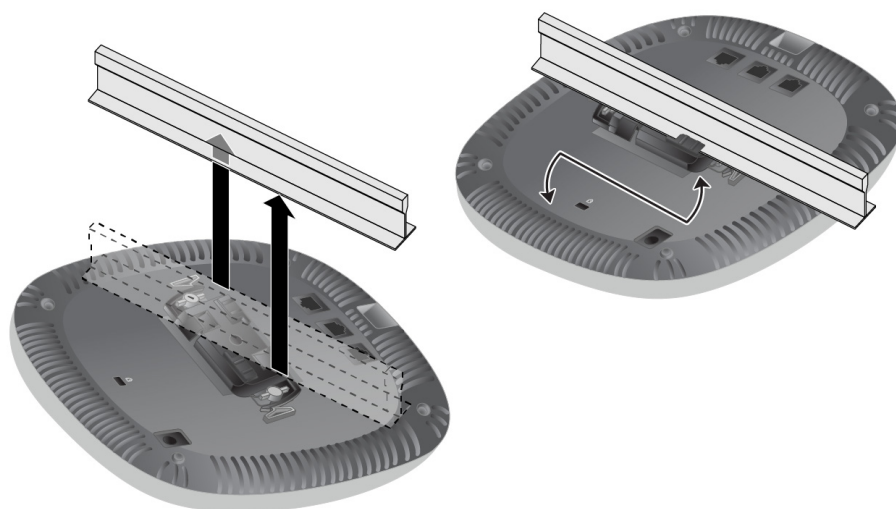

7. On the W-AP334 and W-IAP334 access points, install the external antennas according to the manufacturer's instructions, and connect the antennas to the antenna interfaces on the access point.

Connecting Required Cables

Install cables in accordance with all applicable local and national regulations and practices.

Verifying Post-Installation Connectivity

The integrated LEDs on the access point can be used to verify that the device is receiving power and initializing successfully (see [Table 1](#)). Refer to the *W-Series ArubaOS Quick Start Guide* for further details on verifying post-installation network connectivity.

Configuring the 330 Series



Note: The instructions for the following section are applicable to W-AP334 and W-AP335 access points only.

Access Point Provisioning/Reprovisioning

Provisioning parameters are unique to each access point. These local access point parameters are initially configured on the controller which are then pushed out to the access points and stored on the devices. Dell recommends that provisioning settings be configured via the W-Series ArubaOS Web UI only. Refer to the *W-Series ArubaOS User Guide* for complete details.

Access Point Configuration

Configuration parameters are network or controller specific and are configured and stored on the controller. Network configuration settings are pushed out to the access points, but remain stored on the controller.

Configuration settings can be configured via the W-Series ArubaOS Web UI or W-Series ArubaOS CLI. Refer to their respective guides for further details: the *W-Series ArubaOS User Guide*.

Dell Networking 330 Series Access Points Installation Guide



Contacting Dell

Website Support	
Main Website	dell.com
Contact Information	dell.com/contactdell
Support Website	dell.com/support
Documentation Website	dell.com/support/manuals

Copyright

© 2016 Aruba Networks, Inc. Aruba Networks trademarks include  Airwave, Aruba Networks®, Aruba Wireless Networks®, the registered Aruba the Mobile Edge Company logo, and Aruba Mobility Management System®, Dell™, the DELL™ logo, and PowerConnect™ are trademarks of Dell Inc.

All rights reserved. Specifications in this manual are subject to change without notice. Originated in the USA. All other trademarks are the property of their respective owners.

Open Source Code

Certain Aruba products include Open Source software code developed by third parties, including software code subject to the GNU General Public License (GPL), GNU Lesser General Public License (LGPL), or other Open Source Licenses. The Open Source code used can be found at this site:

http://www.arubanetworks.com/open_source

Includes software from Litech Systems Design. The IF-MAP client library copyright 2011 Infoblox, Inc. All rights reserved. This product includes software developed by Lars Fenneberg, et al.

Legal Notice

The use of Aruba Networks, Inc. switching platforms and software, by all individuals or corporations, to terminate other vendors' VPN client devices constitutes complete acceptance of liability by that individual or corporation for this action and indemnifies, in full, Aruba Networks, Inc. from any and all legal actions that might be taken against it with respect to infringement of copyright on behalf of those vendors.



dell.com

Dell Networking 330 Series Access Points | Installation Guide
Part Number 0511908-04 | August 2016



0511908-04